

Installation - Gutters

Alumasc steel gutters are available in the half round profile in four sizes with a range of brackets to accommodate all types of eaves. The system is dry jointed without the need for additional silicone sealant.

The gutter range can be connected to the steel pipework system and secured by standard pipe clips. The assembly and installation must be considered individually depending on the project, although general aspects of preparation are common to all as shown below.

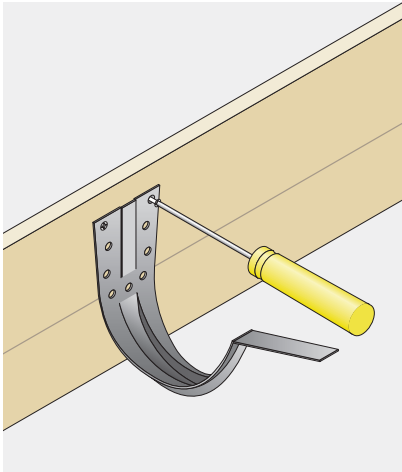

1. Generally position the fascia brackets at 915mm centres, using at least 3 brackets per gutter length. Use 2 screws on both the left and right fixing options and 1/no underneath the gutter securing tab.

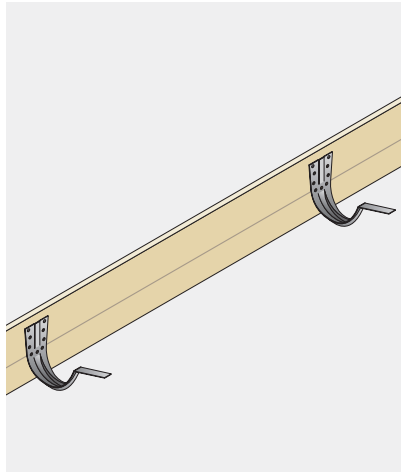

2. Use a string line to set out your fascia brackets along the gutter run allowing for a fall of 1:600 to 1:350 (max).

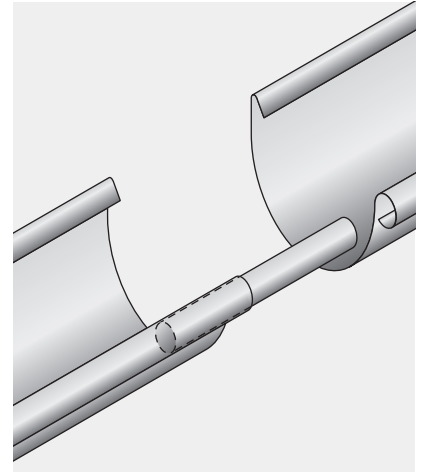

3. A bead connector is used to join two lengths of gutter. Insert the connector into the front roll of each gutter length. Allow for a 4mm expansion gap.

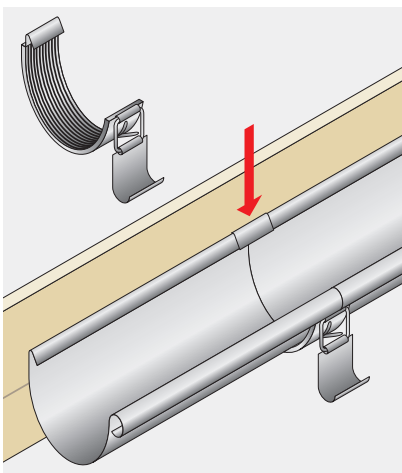

4. An EDPM rubber sealed union connector is used to connect the gutter lengths and angles together. Locate the union connector over the rear edge of the gutter.

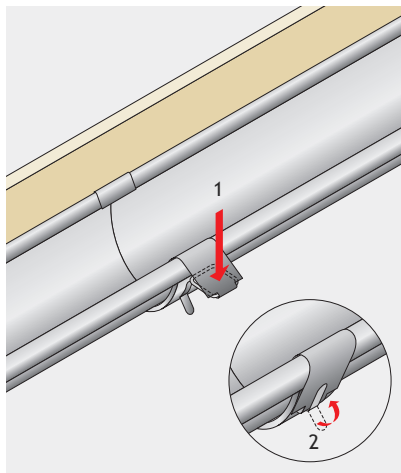

5. Locate the clasp over the front roll edge of the gutter. Push down on top of the clasp and squeeze the clasp shut. Fold the locking tab over to fully secure.

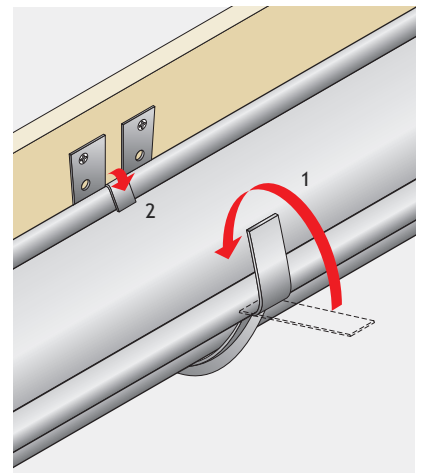

6. Locate the gutter into the fascia bracket and seat level, then fold the front tab of the fascia bracket around the front roll and into the gutter. Fold the rear tab of the fascia bracket down and over the rear edge of the gutter.

For further information or assistance please contact The Rainwater Technical Team on Tel 01744 648400

Installation - Rainwater Pipes

Alumasc steel downpipes are available as a circular profile in 2 sizes with a range of pipe clips and fittings to accommodate all types of installation situations. The downpipes and offsets are push-fit with 'swaged' ends, again for fast and watertight installation.

The assembly and installation must be considered individually depending on the project, although general aspects of preparation are common to all as shown below.

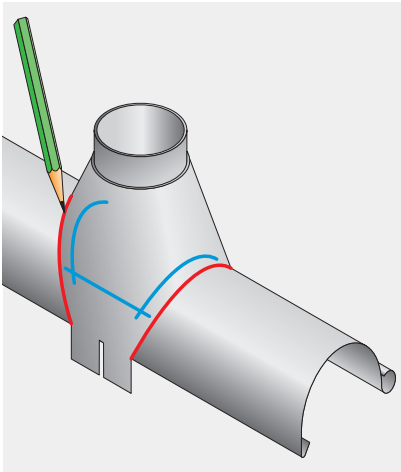

1. When installing a 'wrap around outlet' mark the desired location of the outlet by drawing a line either side of the outlet along its edge. Draw a further line 20mm inside of the outer lines and join these inner lines together in an oval pattern. This becomes the marking for the cut out hole.

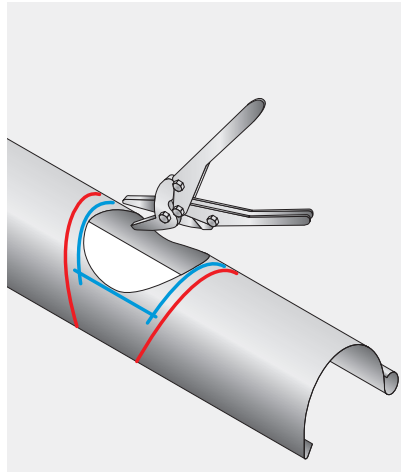

2. Use a hacksaw to make an initial hole in the gutter, and then use a set of tin snips to cut out the inner hole that you have marked out.

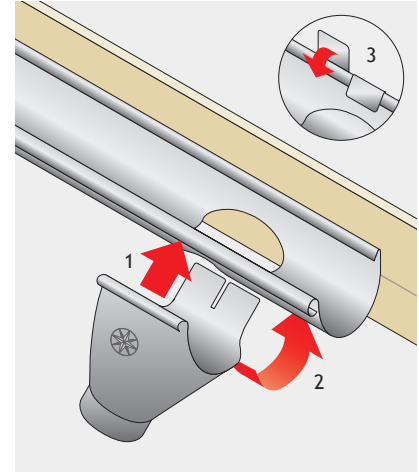

3. Attach the outlet to the gutter and fold the rear tabs of the outlet over the rear edge of the gutter, making sure the outlet is aligned correctly to accept the downpipe.

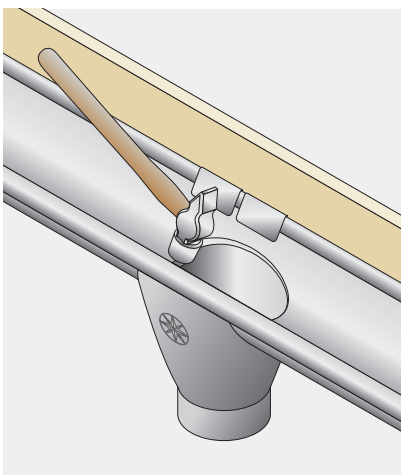

4. Tap the inner rough edges of the hole that was cut in the gutter, down into the outlet, to ensure a smooth flow of water.

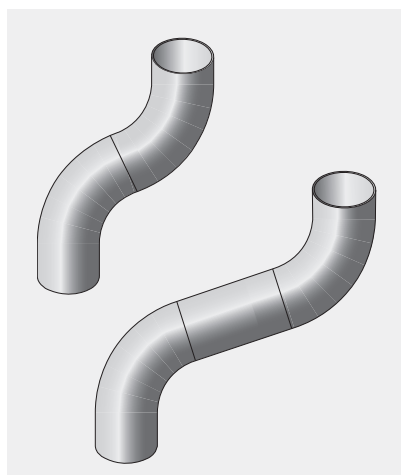

5. Offsets are achieved using 2/no 70° bends, with larger offsets being made by inserting a pipe length between the two bends.

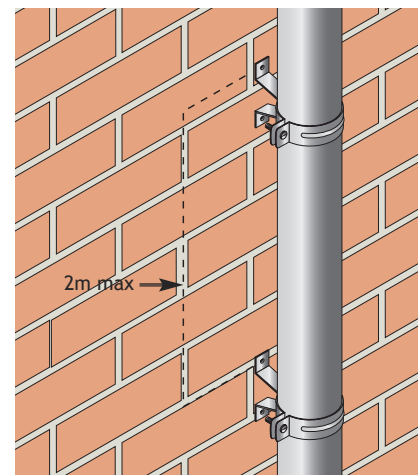

6. Downpipes should be installed using at least 2/no pipe clips per length. Mark out the clips locations and level with a spirit level or plumb line. Open the tightening screw to allow the pipe to be inserted, close the clip and re-tighten, making sure not to over tighten and damage the downpipe.

For further information or assistance please contact The Rainwater Technical Team on Tel 01744 648400